

## Warranty

SPP H3.2 Treated Handrail comes with a 25-year treatment warranty provided you store, install, paint and maintain your product in accordance with manufacturer's guidelines.

SPP H3.1 Treated Handrail comes with a 15-year treatment warranty provided you store, install, paint and maintain your product in accordance with manufacturer's guidelines.

## Building code requirement

The Acceptable Solution D1/AS1 says Clause D1 requires handrails on all stairs. Handrails must be 'positioned between 900 and 1000mm above the pitchline'. The pitchline is defined as 'the line joining the leading edge or nosings of successive stair treads'.

The Acceptable Solution F4/AS1 (Table 1) requires barrier heights in buildings other than housing to be 900mm on stairs and ramps, and 1100mm elsewhere. Thus the barrier height on a landing, other than in housing, must be 1100mm. If the stair handrail is fixed on the top of the stair barrier and carried onto the landing, it will be 1100mm high on the landing. This height is acceptable because the function of a handrail is to provide safety on a stair flight and its height on a landing is not critical. The handrail (and barrier) can rise to the 1100mm height over a transition zone about 300mm long, depending on the stair slope.

## Fixing

Fixing and installation of handrail should be determined by a qualified persons (Builder/Engineer) to provide certainty around the structural integrity of fixings and fixing points.

Recommended spacing: up to a maximum of 1000mm apart - in heavy traffic, commercial and industrial areas we recommend a spacing of 600mm.

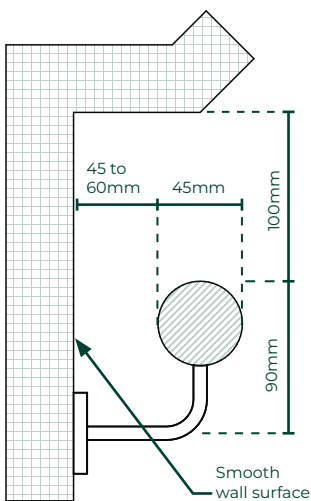
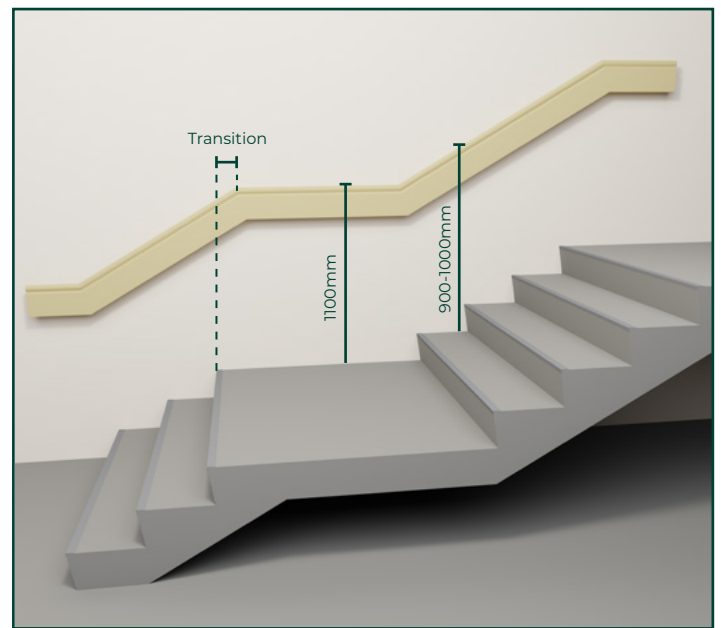

 **ROD & DOWEL 45**  
Accessible Handrail

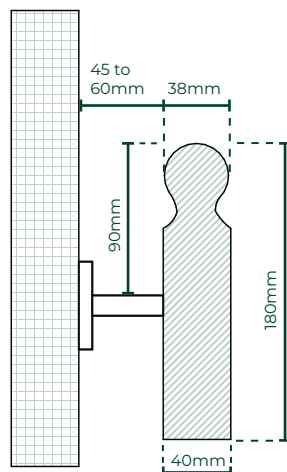

 **EDR180x40**  
Accessible Handrail

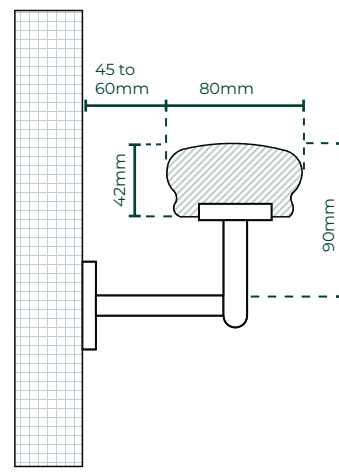

**HR1-80x42**

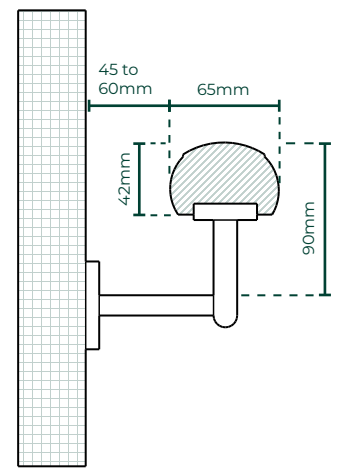

**HR2-65x42**